

**HO  
SCALE**

*Budd*

# Slumbercoach BY RAPIDO



**Travel in efficient and economical style!**

KALUZA-MUELLER COLLECTION

Continuing Rapido's tradition of highly detailed passenger cars, we are proud to introduce the all-new **Budd Slumbercoach in HO scale!**

In the mid 1950s, with passengers quickly switching to airline travel or the private automobile, the Budd company devised the Slumbercoach as an economical way to attract overnight passengers back to the rails. With a capacity of 40 passengers in a 24 single room plus 8 double room plan, the Slumbercoaches offered a lower cost alternative positioned between coach seating and a first class bedroom on overnight runs. A single aisle in the center of the car was flanked by the single and double rooms on each side.

With 18 cars built new between 1956 and 1959, these cars with their distinctive staggered windows could be seen on some of the USA's most famous trains such as the North Coast Limited, Denver Zephyr, National Limited, Texas Eagle and many more.

As delivered, the 18 car Slumbercoach fleet comprised of the following:

- Baltimore & Ohio, 5 cars
- Chicago, Burlington, and Quincy, 4 cars
- Missouri Pacific, 1 car
- New York Central, 4 cars
- Northern Pacific, 4 cars

Later, in 1964 the NP would take ownership of the B&O and MP cars and at least 2 cars ended up with BN lettering briefly in 1970-71. The entire fleet would end up with Amtrak in the 70s and 80s with all cars converted to head end power. Most lasted into the mid to late 90s when they were finally retired and replaced with more modern equipment such as the Superliner II and Viewliners. Most of the fleet still exists today in various states including in museum collections and in private ownership. One car – Loch Ness – has been fully restored by Webb Rail and is operated as a private car.

**All-new from the ground up, the Rapido Slumbercoach features:**

- Designed from original blueprints
- All models based on the as-built steam heat-equipped cars
- Full Rapido level of underbody detail including separate pipes and conduits
- Full multi-color interior detail including roomette doors
- Constant track-powered interior lighting (DC and DCC)
- Accurate GSC 41-NDO-11 trucks with disc brake detail
- Etched-metal end gates and sprung diaphragms
- Rapido's renowned stainless-steel finish
- Separately applied name boards
- Available in multiple paint schemes and a generic painted model ready for custom liveries.

**Order your Slumbercoaches and bring economical comfort to your passenger trains today!**

**MSRP**  
**\$119.95 USD \$139.95 CAD**

**ORDER DEADLINE:**  
**DECEMBER 15<sup>TH</sup>, 2022**



CANADA: 500 ALDEN ROAD • UNIT 21 • MARKHAM • ONTARIO • L3R 5H5  
USA: PO BOX 796 • HIGGANUM • CONNECTICUT • 06441  
Tel. 905.474.3314. Fax. 905.474.3325. Visit. [www.rapidotrains.com](http://www.rapidotrains.com)

**RAPIDO**



# SLUMBERCOACH SERVICE

BROUGHT TO YOU BY RAPIDO

**Order Deadline:  
December 15<sup>TH</sup>, 2022**

**This is your brain on trains.**

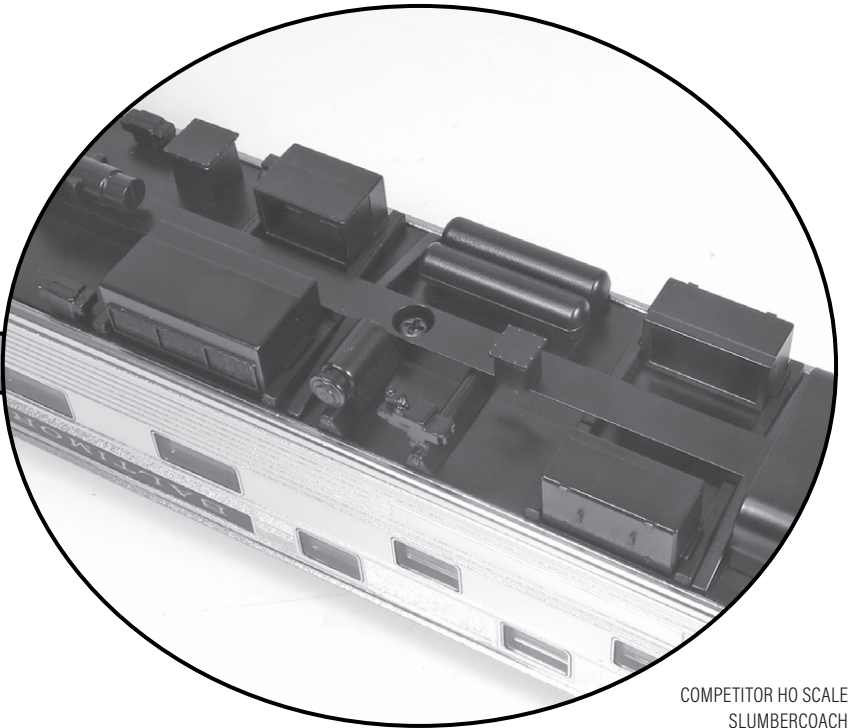

COMPETITOR HO SCALE  
SLUMBERCOACH

**This is your brain on Rapido Trains.**

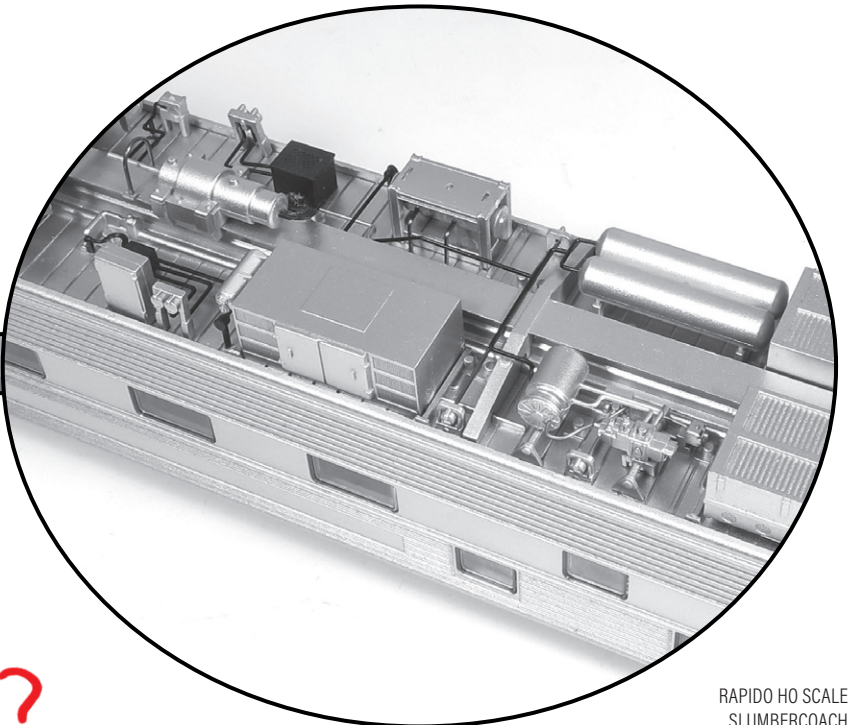

RAPIDO HO SCALE  
SLUMBERCOACH

**ANY QUESTIONS?**

**Partnership For A Rapido-Full America.**

ORDER YOUR HO SCALE SLUMBERCOACH TODAY. [RAPIDOTRAINS.COM](http://RAPIDOTRAINS.COM)



**HO  
SCALE****Build Slumbercoach**DEALER INFO:  
**AMTRAK (PHASE 1)**

1971-1980

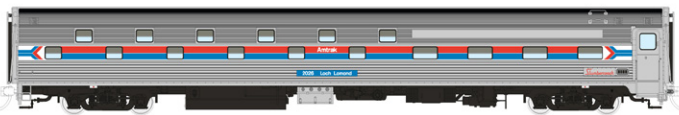

- 141001 — #2024 LOCH SLOY
- 141002 — #2026 LOCH LOMOND
- 141003 — #2027 LOCH NESS
- 141004 — #2028 LOCH TARBET

**AMTRAK (PHASE 3)**

1981-1996

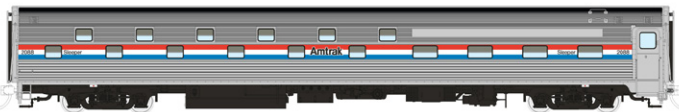

- 141005 — #2081 LOCH LONG
- 141006 — #2088 LOCH LEVEN
- 141007 — #2092 LOCH ARKAIG
- 141008 — #2093 LOCH KATRINE

**BALTIMORE & OHIO**

1958-1964



- 141009 — #7700 SLUMBERLAND
- 141010 — #7701 DREAMLAND
- 141011 — #7702 RESTLAND
- 141012 — #7703 SLEEPLAND
- 141013 — #7704 THRIFTLAND

**BURLINGTON NORTHERN**

1970-1974

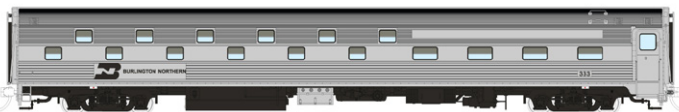

- 141014 — #333 LOCH TAY
- 141015 — #1489 LOCH RANNOCH

**CHICAGO, BURLINGTON & QUINCY (NP)**

1965-1970



- 141016 — #335 LOCH ARKAIG
- 141017 — #336 LOCH AWE

OWNERSHIP OF THESE CARS WAS TRANSFERRED FROM NORTHERN PACIFIC IN 1965 FOR USE ON THE JOINT NP/CB&Q NORTH COAST LIMITED. ALTHOUGH THEY RETAINED THE NP LETTERING, THEY WERE SUB-LETTERED CB&Q.

**MISSOURI PACIFIC**

1959-1964



- 141018 — #699 SOUTHLAND

**NEW YORK CENTRAL "SLEEPERCOACH"**

1959-1964



- 141019 — #10800
- 141020 — #10801
- 141021 — #10802
- 141022 — #10803

**NORTHERN PACIFIC**

1959-1970



- 141023 — #325 LOCH SLOY
- 141024 — #326 LOCH LEVEN
- 141025 — #327 LOCH LOMOND
- 141026 — #328 LOCH NESS

**PAINTED, UNLETTERED**

- 141099 — PAINTED, UNLETTERED

PAINTED, UNLETTERED CARS COME WITH DECORATED "SLUMBERCOACH" AND "PULLMAN" BOARDS, AS WELL AS VARIOUS LENGTHS OF UNDECORATED NAME BOARDS, IN A POLYBAG.



Early pre-production sample. Subject to revision.

**MSRP \$119.95 USD \$139.95 CAD ORDER DEADLINE: DECEMBER 15<sup>TH</sup>, 2022**



CANADA: 500 ALDEN ROAD • UNIT 21 • MARKHAM • ONTARIO • L3R 5H5  
 USA: PO BOX 796 • HIGGANUM • CONNECTICUT • 06441  
 Tel. 905.474.3314. Fax. 905.474.3325. Visit. [www.rapidotrains.com](http://www.rapidotrains.com)

**RAPIDO**