

HO SCALE

PACIFIC CAR & FOUNDRY

# B-100-40 BOXCAR

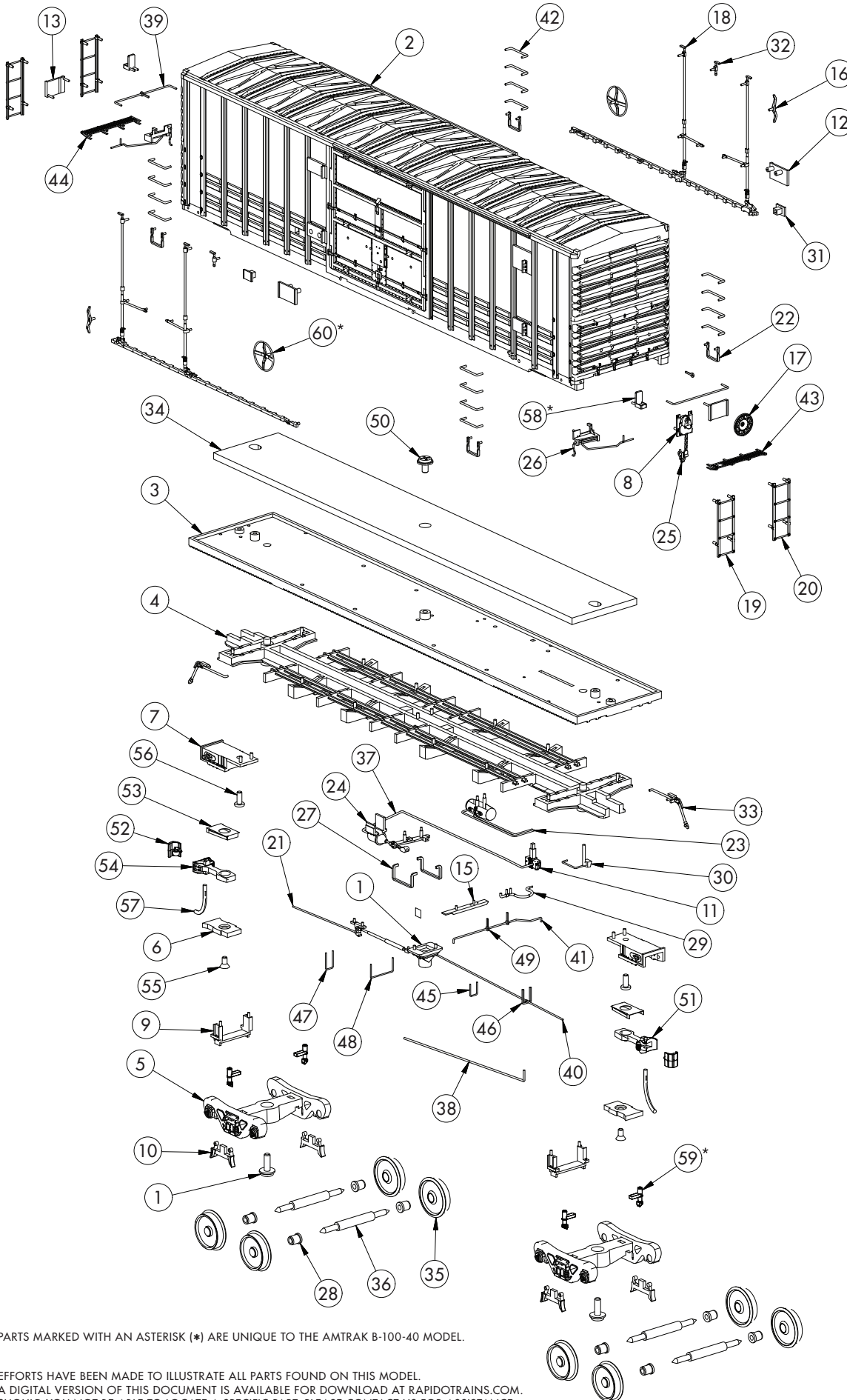

60*	137-04-10	2
59*	137-03-13	4
58*	137-03-11	2
57	COUPLER PIN	2
56	SCREW 1.4x3.5 C	2
55	SCREW 1.4x3 KA	2
54	GF-06-M002	2
53	GF-06-M001 R1 STP	2
52	GF-06-02	2
51	GF-06-01	2
50	SCREW 1.7x3 PWB	1
49	137-MT016	4
48	137-MT015	1
47	137-MT014	1
46	137-MT013	1
45	137-MT012	1
44	137-MT011	1
43	137-MT010	1
42	137-MT009	16
41	137-MT008	1
40	137-MT007	1
39	137-MT006	2
38	137-MT005	1
37	137-MT004	1
36	137-MT003	4
35	137-MT002	8
34	137-MT001	1
33	137-05-01	2
32	137-04-16	2
31	137-04-15	2
30	137-04-14	1
29	137-04-13	1
28	137-04-12	8
27	137-04-11	2
26	137-04-09	2
25	137-04-08	1
24	137-04-07	1
23	137-04-06	1
22	137-04-05	4
21	137-04-04	1
20	137-04-03	2
19	137-04-02	2
18	137-04-01	2
17	137-03-15	1
16	137-03-14	2
15	137-03-12	1
14	137-03-10	1
13	137-03-09	2
12	137-03-08	2
11	137-03-07	1
10	137-03-06	4
9	137-03-05	2
8	137-03-04	1
7	137-03-03	2
6	137-03-02	2
5	137-03-01	2
4	137-02-02	1
3	137-02-01	1
2	137-01-01	1
1	SCREW 1.7x5 PWB	2
PC NO	PART NAME	QTY

PARTS MARKED WITH AN ASTERISK (\*) ARE UNIQUE TO THE AMTRAK B-100-40 MODEL.

EFFORTS HAVE BEEN MADE TO ILLUSTRATE ALL PARTS FOUND ON THIS MODEL. A DIGITAL VERSION OF THIS DOCUMENT IS AVAILABLE FOR DOWNLOAD AT RAPIDOTRAINS.COM. SHOULD YOU NOT BE ABLE TO LOCATE A SPECIFIC PART, PLEASE CONTACT US FOR ASSISTANCE.